

Clarke®



WARNING: Read these instructions before using the machine

ELECTRIC CHAINSAW SHARPENER

MODEL NO: ECSS3

PART NO: 3402081

OPERATION & MAINTENANCE INSTRUCTIONS

UK
CA | CE



ORIGINAL INSTRUCTIONS

DL1124

INTRODUCTION

Thank you for purchasing this CLARKE Electric Chainsaw Sharpener.

Please read this manual thoroughly, before attempting to operate, and carefully follow all instructions given.

It is vitally important that ALL precautions are taken, as specified, which will not only provide protection for yourself and that of others around you, but will also ensure that the product will give you long and satisfactory service.

GUARANTEE

This CLARKE product is guaranteed against faulty manufacture for a period of 12 months from the date of purchase. Please keep your receipt as proof of purchase.

This guarantee is invalid if the product is found to have been abused or tampered with in any way, or not used for the purpose for which it was intended.

Faulty goods should be returned to their place of purchase, no product can be returned to us without prior permission.

This guarantee does not affect your statutory rights.

ENVIRONMENTAL PROTECTION



Recycle unwanted materials instead of disposing of them as waste. All tools, accessories and packaging should be sorted, taken to a recycling centre and disposed of in a manner which is compatible with the environment.

SAFETY PRECAUTIONS



WARNING: READ ALL INSTRUCTIONS. FAILURE TO FOLLOW ALL INSTRUCTIONS LISTED BELOW MAY RESULT IN ELECTRIC SHOCK, FIRE AND/OR SERIOUS INJURY. THE TERM "POWER TOOL" IN ALL WARNINGS LISTED BELOW REFERS TO YOUR ELECTRIC CHAINSAW SHARPENER.

WORK AREA

1. **Keep work area clean and well lit.** Cluttered and dark areas invite accidents.
2. **DO NOT operate power tools in explosive atmospheres, such as in the presence of flammable liquids, gases or dust.** Power tools create sparks which may ignite the dust or fumes.
3. **Keep children and bystanders away while operating a power tool.** Distractions can cause you to lose control.

ELECTRICAL SAFETY

1. **Avoid body contact with earthed or grounded surfaces such as pipes, radiators, ranges or refrigerators.** There is an increased risk of electric shock if your body is earthed or grounded.
2. **DO NOT expose power tools to rain or wet conditions.** Water entering a power tool will increase the risk of electric shock.
3. **When operating a power tool outdoors, use an extension cord suitable for outdoor use.** Use of a cord suitable for outdoor use reduces the risk of electric shock.

PERSONAL SAFETY

1. **Stay alert, watch what you are doing and use common sense when operating a power tool. DO NOT use a power tool while you are tired or under the influence of drugs, alcohol or medication.** A moment of inattention while operating power tools may result in personal injury.
2. **Use safety equipment (PPE). Always wear eye protection.** Safety equipment such as dust mask, non-skid safety shoes, or hearing protection used for appropriate conditions will reduce personal injuries.
3. **Avoid accidental starting. Ensure the switch is in the off position before connecting to the power supply.**
4. **DO NOT overreach. Keep proper footing and balance at all times.** This enables better control of the power tool in unexpected situations.

5. **Dress properly. DO NOT wear loose clothing or jewellery. Keep your hair and clothing away from moving parts.** Loose clothes, jewellery or long hair can be caught in moving parts.

POWER TOOL USE AND CARE

1. **DO NOT force the power tool. Use the correct power tool for your application.** The correct power tool will do the job better and safer at the rate which it was designed.
2. **DO NOT use the power tool if the switch does not turn it on and off.** Any power tool that cannot be controlled with the switch is dangerous and must be repaired.
3. **Disconnect the battery before making any adjustments, changing accessories, or storing power tools.** Such preventive safety measures reduce the risk of starting the power tool accidentally.
4. **Store idle tools out of the reach of children and DO NOT allow persons unfamiliar with the power tool or these instructions to operate the power tool.** Power tools are dangerous in the hands of untrained users.
5. **Maintain power tools. Check for misalignment or binding of moving parts, breakage of parts and any other condition that may affect the power tools operation. If damaged, have the power tool repaired before use.** Many accidents are caused by poorly maintained power tools.
6. **Keep cutting tools sharp and clean.** Poorly maintained cutting tools with sharp cutting edges are less likely to bind and are easier to control.
7. **Use the power tool and accessories in accordance with these instructions and in the manner intended for the particular type of power tool, taking into account the working conditions and the work to be performed.** Use of the power tool for operations different from intended could result in a hazardous situation.

SERVICING

1. **Have your power tool serviced by a qualified repair person using only identical replacement parts.** This will ensure that the safety of the power tool is maintained.

ADDITIONAL SAFETY INSTRUCTIONS FOR CHAINSAW SHARPENERS

1. **WARNING:** Sharp edges on blade/chain.
2. Remember that the wheel continues to rotate after the tool is switched off.
3. **ALWAYS** wear safety eye protection when using the sharpener.
4. The sharpener is designed for sharpening the majority of common chainsaw chains. **DO NOT** use it for any other purpose.
5. **DO NOT** sharpen damaged chainsaw chains.
6. **ALWAYS** make sure the sharpener is firmly fixed to a workbench before use.
7. **DO NOT** operate the sharpener without the protective cover in place and make sure that all parts are firmly assembled before starting the sharpener.
8. **DO NOT** operate the sharpener if it does not work correctly or has been damaged.

SPECIFICATIONS

Operating Voltage:	230 V @ 50 Hz
Nominal Power	85 Watts
Protection Class	II
IP Rating	IP20
Motor Speed	5800 rpm
Grinding Wheel Speed Rating	40 m/s, 7074 rpm
Disc Dimensions	108 mm (Diameter) x 3.2 mm (Thick)
Arbor/Bore Diameter	23 mm
Sharpening Angle	35° Right to Left
Dimensions (W x D x H)	180 x 230 x 320 mm
Weight (kg)	2 kg

ELECTRICAL CONNECTIONS



WARNING: READ THESE ELECTRICAL SAFETY INSTRUCTIONS THOROUGHLY BEFORE CONNECTING THE PRODUCT TO THE MAINS SUPPLY.

Before switching the product on, make sure that the voltage of your electricity supply is the same as that indicated on the rating plate. This product is designed to operate on 230V AC 50Hz. Connecting it to any other power source may cause damage.

This product may be fitted with a non-rewireable plug. If it is necessary to change the fuse in the plug, the fuse cover must be refitted. If the fuse cover becomes lost or damaged, the plug must not be used until a suitable replacement is obtained.

If the plug has to be changed because it is not suitable for your socket, or due to damage, it should be cut off and a replacement fitted, following the wiring instructions shown below. The old plug must be disposed of safely, as insertion into a mains socket could cause an electrical hazard.

If the colours of the wires in the power cable of this product do not correspond with the markings on the terminals of your plug, proceed as follows.

- The **Blue** wire must be connected to the terminal marked **N** or coloured **Black**.
- The **Brown** wire must be connected to the terminal marked **L** or coloured **Red**.

Plug must be BS1363/A approved.

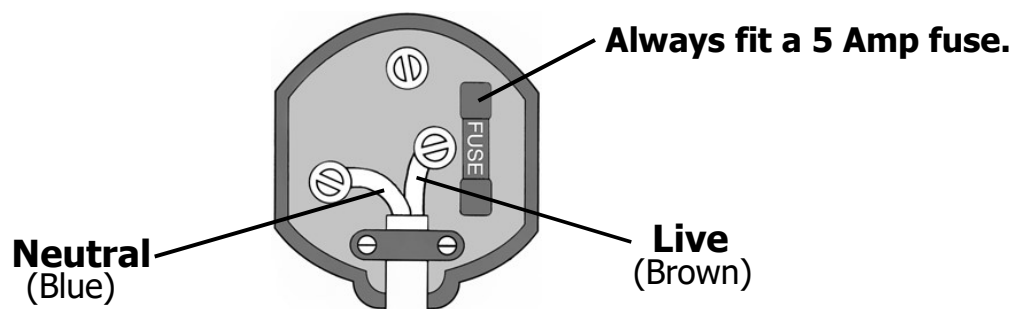

Ensure that the outer sheath of the cable is firmly held by the clamp

We strongly recommend that this machine is connected to the mains supply via a Residual Current Device (RCD)

If in any doubt, consult a qualified electrician. **DO NOT** attempt any repairs yourself.



This symbol indicates that this is a Class II product, and does not require an earth connection.

OVERVIEW

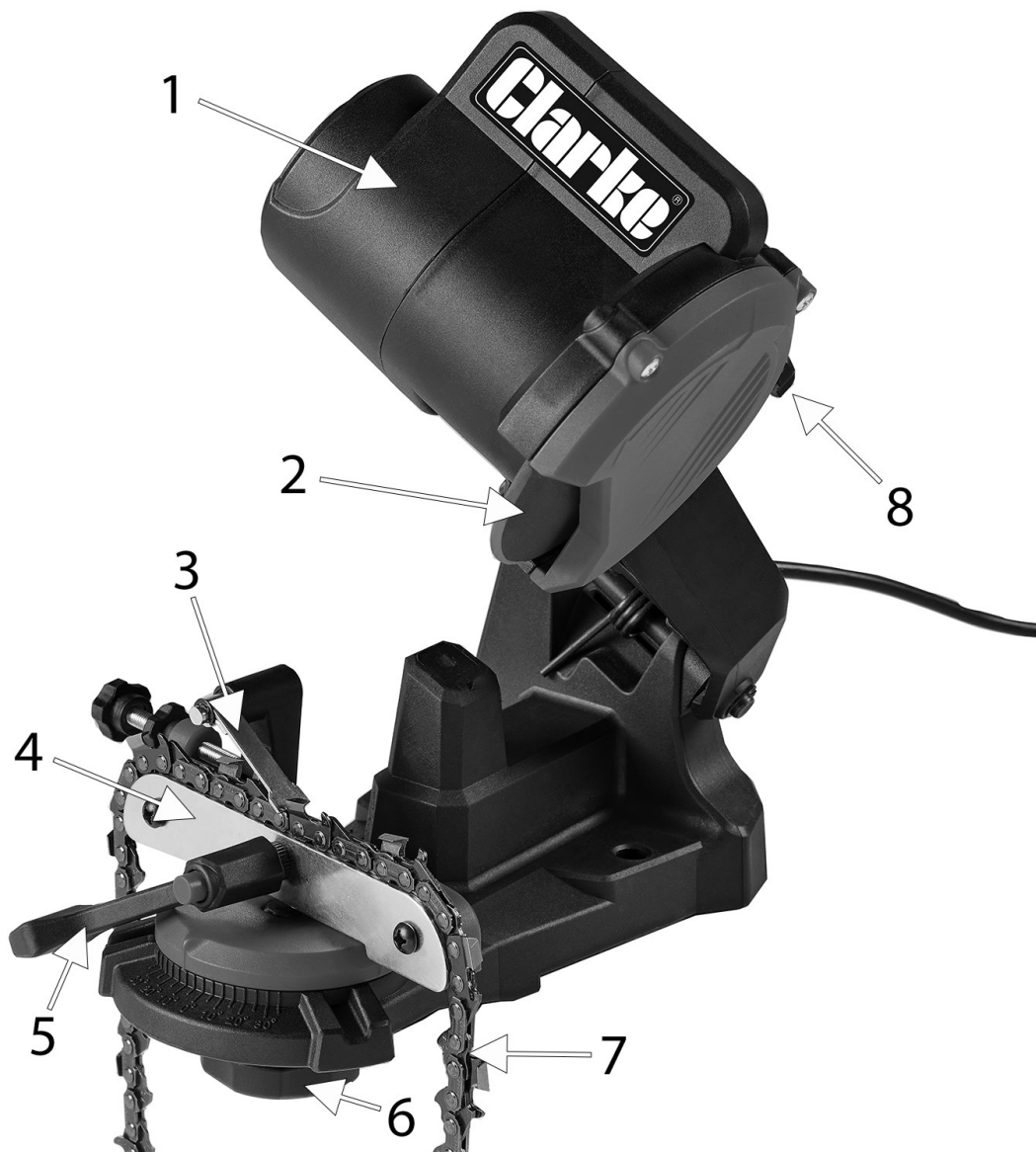

No	Description
1	Motor Casing
2	Grinding Wheel
3	Chain Stop
4	Sliding Guide

No	Description
5	Locking Handle
6	Locking Wheel
7	Chainsaw Blade (Not Included)
8	Depth Lock Stop

ASSEMBLY



WARNING: MAKE SURE THE SHARPENER IS NOT CONNECTED TO THE MAINS POWER SUPPLY DURING SETUP.

WARNING: NEVER OPERATE THE TOOL WITHOUT THE GRINDING WHEEL COVER IN PLACE.

1. Insert the chain holder assembly into the base as shown and secure from below using the Locking Wheel supplied.
 - Make sure the pointer is positioned pointing forwards (away from the grinding wheel).

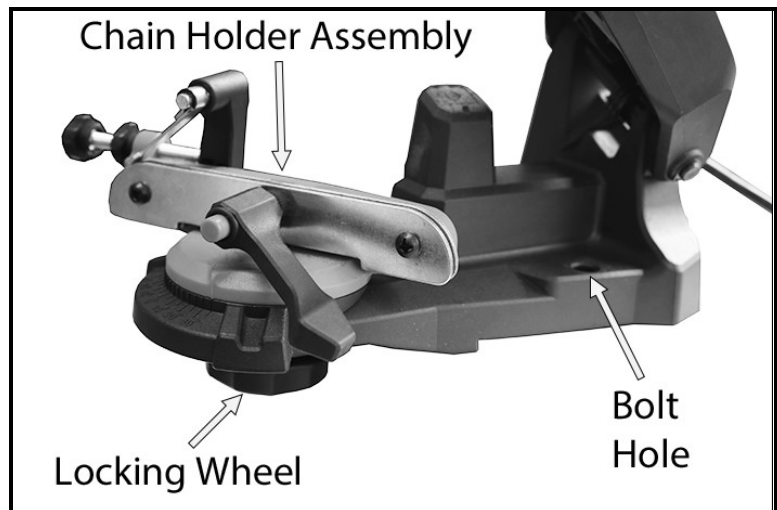

2. Bolt (bolts not included) the unit directly to the workbench through the two 1/4" holes in the base. Making sure the Locking Wheel is overhanging the edge of the workbench, with enough room to turn it.
 - The workbench must have a solid surface capable of supporting the weight of the sharpener and the work piece.

OPERATION



WARNING: WHEN SHARPENING, ALWAYS WEAR SAFETY GOGGLES.

WARNING: ALWAYS SWITCH OFF THE TOOL WHEN ADJUSTING THE CHAIN FOR SHARPENING.

NOTE: Sharpen all the teeth on one side first (every other tooth) before adjusting the angle to complete the job.

NOTE: ALWAYS raise the Top Housing while adjusting the chain.

1. Put on protective goggles and make sure the immediate area is clear of bystanders.
2. Clean the chain before sharpening it. Wash it with a non-flammable solvent. **DO NOT** use petrol or diesel. Dry the chain.

3. Lift up the Chain Stop and place the chain in the Sliding Guide, as shown.

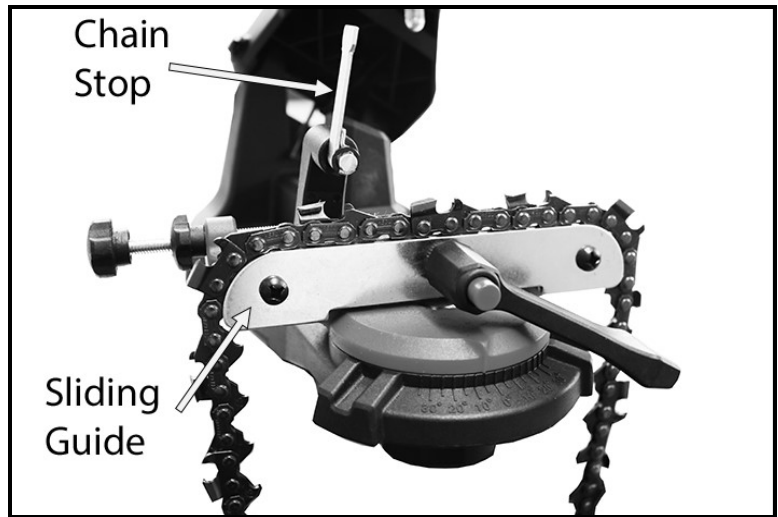

4. Lower the Chain Stop so that it is positioned on the tooth (blade) you want to start with, using the adjustment knob and locking nut to position the Chain Stop as required.
5. Loosen the Lock Wheel to allow the entire housing to turn. Rotate the housing to match the degree of angle you need on the Angle Gauge.

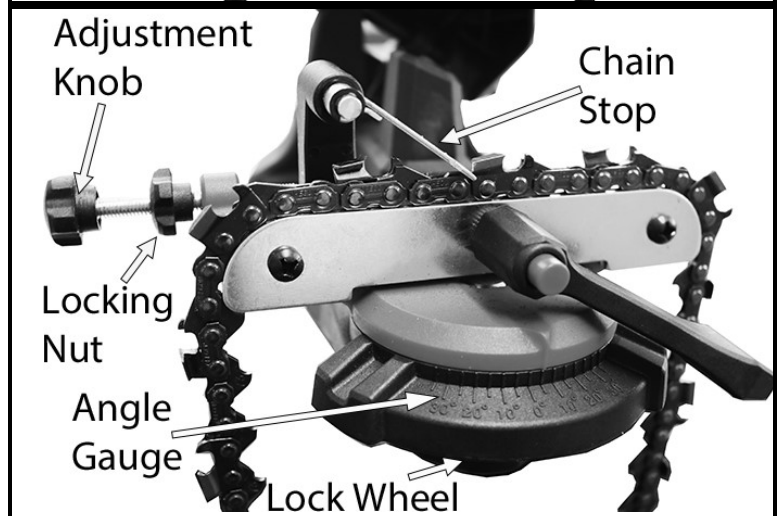

NOTE: Chains come in various sizes with varying degrees of sharpening angles. Check with the chain manufacturers manual to determine what degree you need to sharpen at.

6. Once the degree is set, tighten the Lock Wheel.
7. Lower the Top Housing so that the Grinding Wheel skims the chain tooth.
8. Hold it at that position while you adjust the Depth Lock Stop so that the Grinding Wheel will only go down to that point.
9. Depending on the amount of material you wish to remove, tighten or loosen the Depth Lock Stop and set the Lock Nut.

NOTE: Once the Depth Lock Stop is set, fully tighten the Lock Nut.

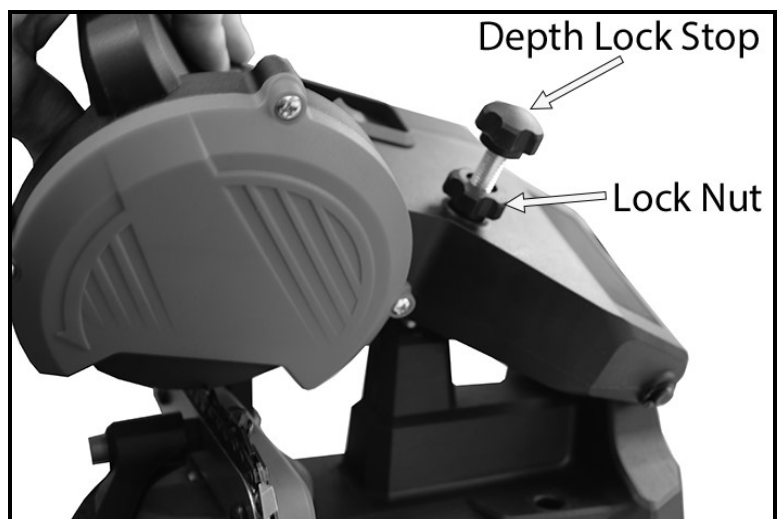

10. Lock the chain in the Sliding Guide by turning the Handle.

NOTE: The Handle should be situated so that you can easily release and tighten it. You will need to release it each time you move to the next link, and tighten it to sharpen each link.



11. If the chain has been repeatedly sharpened, the chain depth limiter gauges may need to be taken down with a flat file (not included).

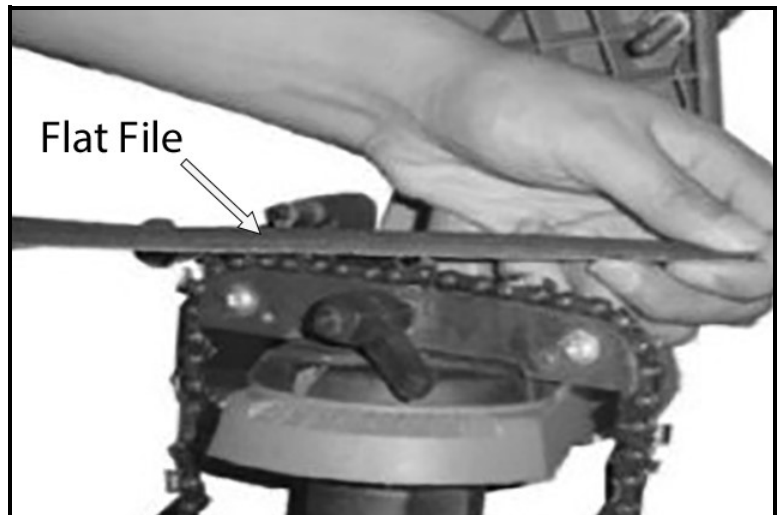

12. File down each gauge so that they are at a lower level than the cutting teeth.

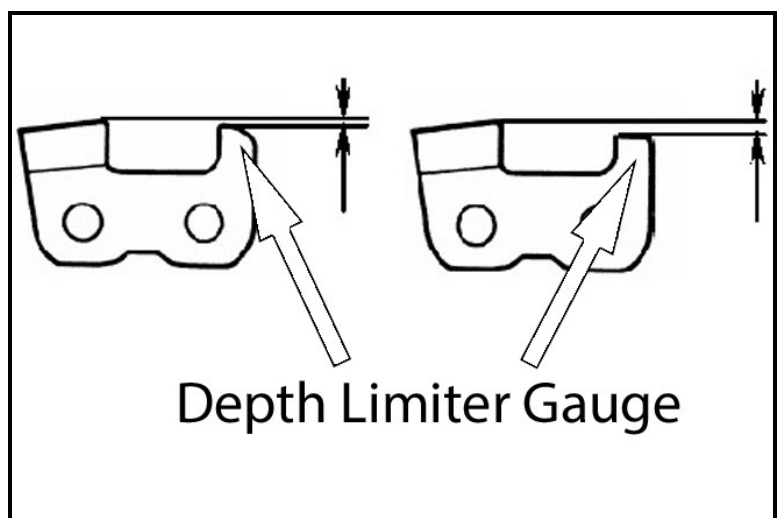

SHARPENING



WARNING: WHEN SHARPENING, ALWAYS WEAR SAFETY GOGGLES AND MAKE SURE THE IMMEDIATE AREA IS CLEAR OF BYSTANDERS.

1. Plug in the sharpener and press the start button to the 'ON' position.

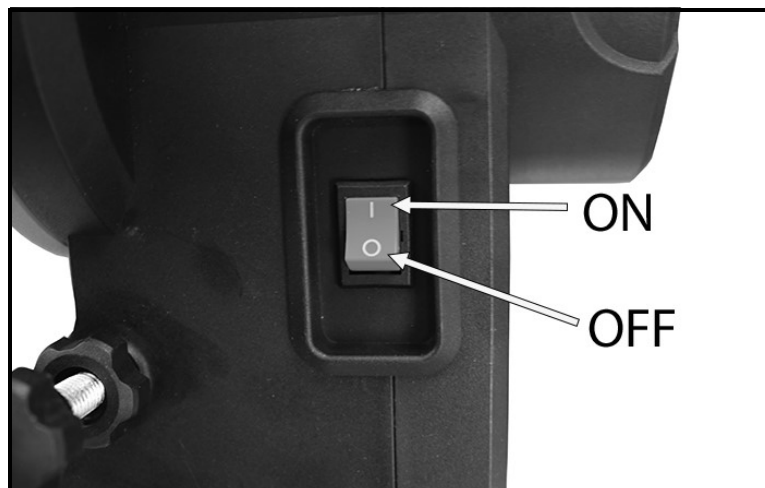

2. Slowly lower the grinding wheel towards the chain.

NOTE: If you notice slight errors in your settings, turn off the sharpener and unplug it before you make any adjustments.

NOTE: A good grind occurs when the contact between the wheel and the teeth are gradual and smooth. **DO NOT** stop for too long on each tooth.

3. After sharpening one tooth, turn off the sharpener. Lift the Top Housing, release the locking handle on the chain holder and move the chain so that the next link is positioned in the Chain Stop.
4. Tighten the locking handle on the chain holder. Turn the sharpener back on and continue sharpening the next tooth.
5. Repeat this process until you have sharpened all the links set up for this angle.
6. After you have finished sharpening all the teeth on the chain at this angle, turn off the sharpener by pushing the start button to the 'OFF' position and unplugging the unit.
7. Loosen the Lock Wheel and reset the angle so that the first tooth that hasn't been sharpened is positioned against the Chain Stop and locked in as explained on pages 8-10.
8. As you did with the first half of the chain, be sure to lower the Top Housing so that the Grinding Wheel skims the chain tooth and lock it in place.
9. Follow all the steps on pages 8-10 double checking everything before you plug the sharpener in and turn it on.
10. After you have repeated all the steps in pages 8-12, your chain is ready to be remounted on the saw.

OPERATING HINTS

- Before you sharpen the chainsaw chain check it for damage, such as:- bent or abraded chain links.- broken cutting teeth, loose rivets or broken rivet heads.If any damage is found, replace the entire chain.
- A sharp chainsaw produces wood chips and pulls itself into the timber being cut. When it becomes blunt, sawdust will start being produced during cutting operations.You should sharpen the chain if you notice that you have to use force to cut through the timber, i.e. if the saw does not "pull" anymore.

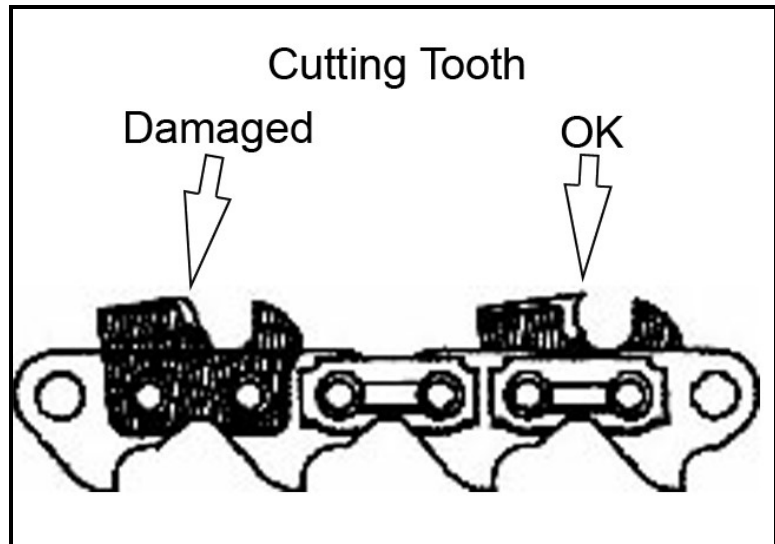

- Sharpen all cutting teeth as uniformly as possible. This will ensure smooth operation with a minimum of vibration.
- Blunt cutting teeth or parts damaged by stones may cause an inclined cut during chain saw operation, and may also increase the wear on the running face of the cutting teeth.
- The depth limiter gauge must be profiled by hand. Ensure that all depth limiter bars are equal in height.
- Ensure that all cutting teeth are sharpened to the same cutting angle.

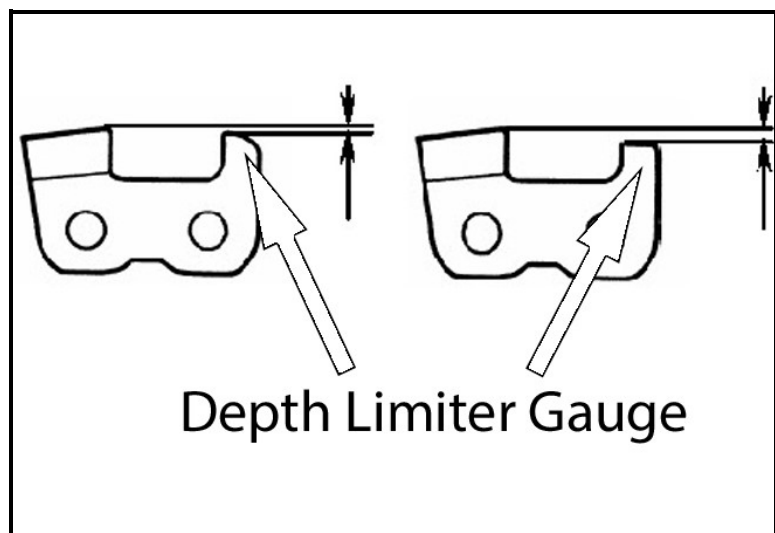

- During sharpening occasionally check that the cutting-angle is set correctly, as this setting may go out of adjustment due to vibration.
- Make sure that all teeth are sharpened as evenly as possible. Only sharpen the teeth, never sharpen the chain links.
- Sharpening teeth to unequal lengths can cause a side drift when sawing.

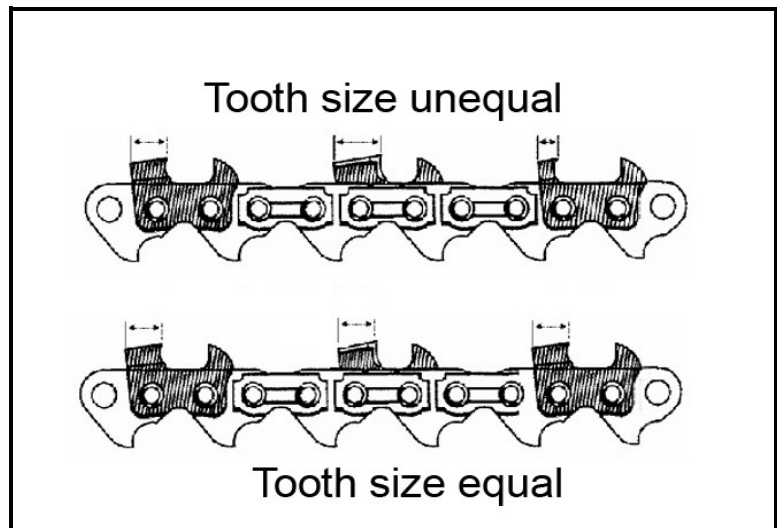

CLEANING AND MAINTENANCE



WARNING: BEFORE STARTING ANY CLEANING OR MAINTENANCE PROCEDURES, DISCONNECT THE PLUG FROM MAINS SUPPLY.

1. Keep the tool clean and free of dust, metal debris and dirt.

NOTE: NEVER clean the tool with any flammable liquid.

2. Check the grinding wheel before each use to make sure it isn't damaged. **DO NOT** use a grinding wheel if it is chipped, cracked or worn. You can check if the wheel has cracks not visible to the human eye by hanging it up by the central hole and tapping it with a non metallic object (ie a screwdriver handle). If it is in a good condition it will produce a metallic sound. A dull sound indicates a crack or break.
3. Replace the grinding wheel when it grinds down to a diameter of 3 inches/7.62cm.
 - Replacement discs are available from your CLARKE dealer: part number (3402079).



WARNING: NEVER OPERATE THE SHARPENER WITHOUT THE GRINDING WHEEL COVER IN PLACE.

MOUNTING A GRINDING WHEEL

1. Turn off the sharpener and remove the power cable from the power socket.
2. Lay the sharpener on its side.
3. Remove the three screws that are holding the Grinding Wheel Cover and set aside. Remove the Grinding Wheel Cover.

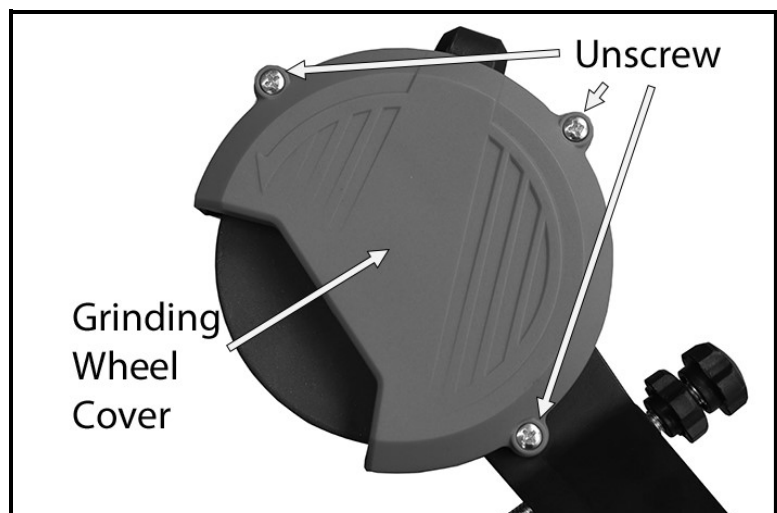

4. Unscrew the Grinder Lock Cap that holds the Grinding Wheel in place and remove the Grinding Wheel.

5. Install the new wheel on the Grinding Wheel Base, making sure it fits correctly.

NOTE: DO NOT use a grinding wheel if it is chipped, cracked or worn. You can check if the wheel has cracks not visible to the human eye by hanging it up by the central hole and tapping it with a non metallic object (ie a screwdriver handle). If it is in a good condition it will produce a metallic sound. A dull sound indicates a crack or break.

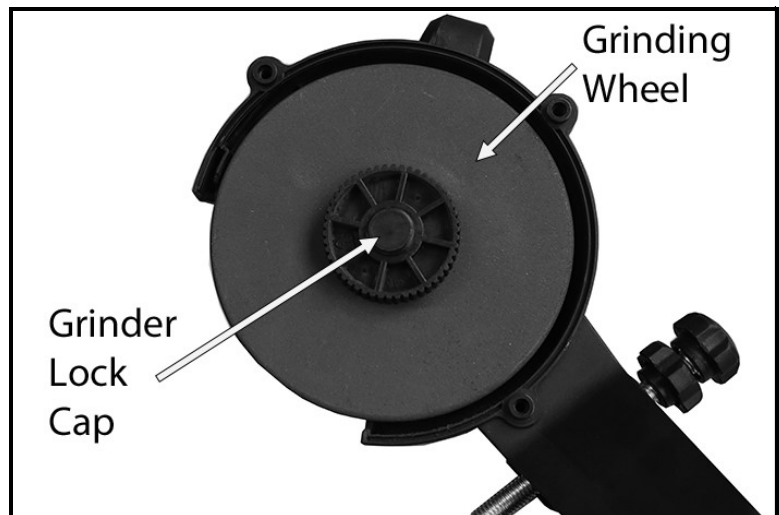

6. Replace and tighten the Grinder Lock Cap.

7. Replace the Grinding Wheel Cover and the three screws.

PARTS DIAGRAM

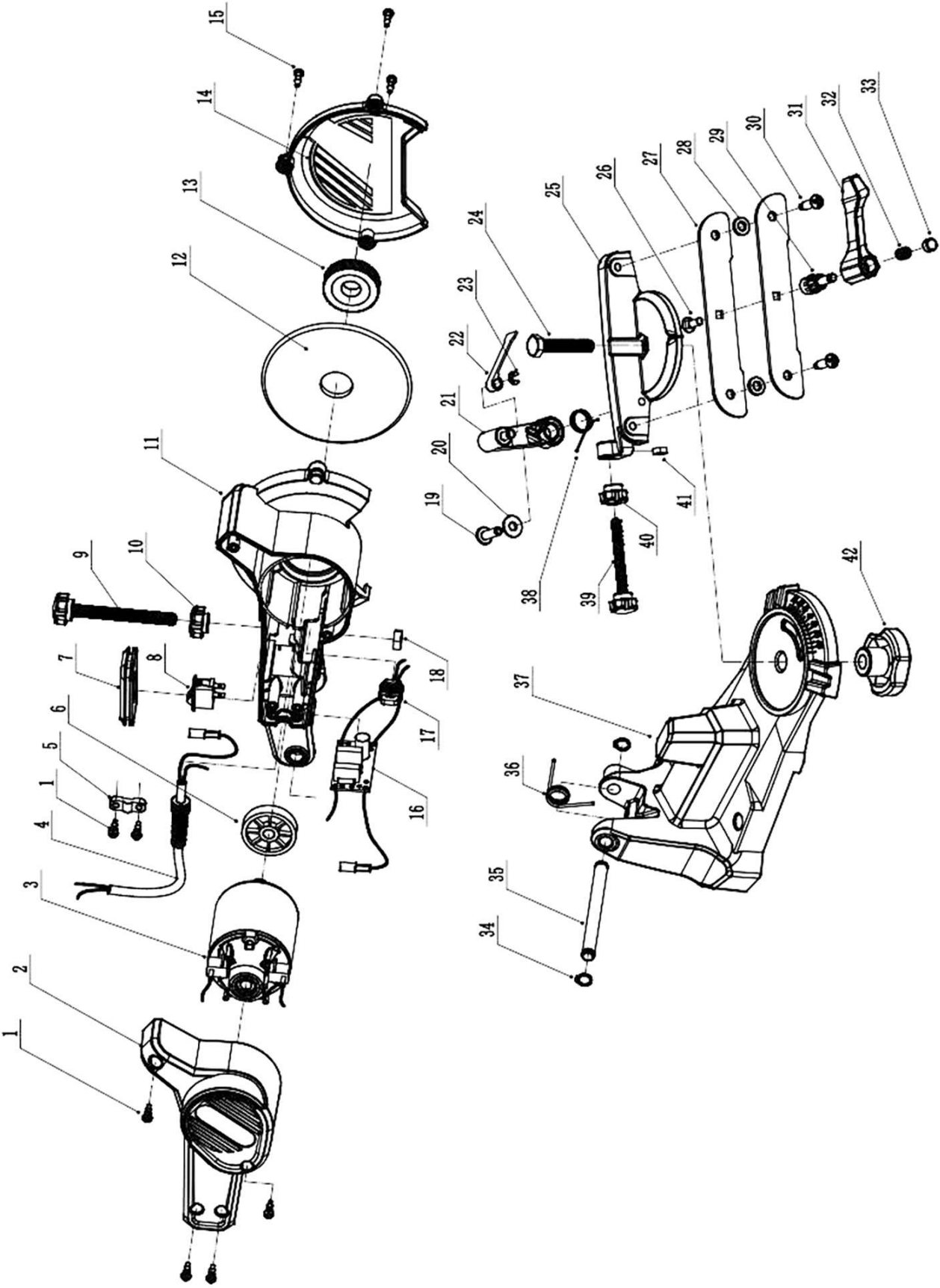

PARTS LIST

No	Description
1	Screw (x6)
2	Motor Cover
3	Motor
4	Power Cable
5	Cable Holding Plate
6	Grinding Wheel Base
7	Switch Plate
8	On/Off Switch
9	Lock Stop Screw
10	Lock Stop Nut
11	Main Housing
12	Grinding Wheel
13	Grinding Lock Cap
14	Grinding Wheel Cover
15	Screw (x3)
16	PCB
17	Conductor
18	Lock Stop Nut
19	Screw
20	Pad
21	Swing Arm

No	Description
22	Chain Stop
23	Washer
24	Locking Wheel Bolt
25	Chainsaw Frame
26	Screw
27	Sliding Guide (x2)
28	Spacing Pad (x2)
29	Nut
30	Screw (x2)
31	Locking Handle
32	Spring
33	Lock Nut
34	Washer (x2)
35	Punching Axis
36	Torsion Spring
37	Base
38	Spring
39	Lower Knob Screw
40	Lock Nut
41	Nut
42	Locking Wheel

DECLARATION OF CONFORMITY - UKCA

**UK
CA**

Clarke[®]
INTERNATIONAL

Hemnall Street, Epping, Essex, CM16 4LG

DECLARATION OF CONFORMITY

This is an important document and should be retained.

We hereby declare that this product(s) complies with the following legislation:

The Electromagnetic Compatibility Regulations 2016

The Supply of Machinery (Safety) Regulations 2008

The Restriction of the Use of Certain Hazardous Substances in Electrical and Electronic Equipment Regulations 2012

The following standards have been applied to the product(s):

*EN 62841-3-10:2015+AC:2016+A11:2017, IEC 62321-1:2013, IEC 62321-2:2021, IEC 62321-5:2013,
EN IEC 61000-3-2:2019+A1:2021, IEC 62321-7-1:2015, IEC 62321-7-2:2017, EN IEC 55014-1:2021,
EN 61000-3-3:2013+A1:2019+A2:2021, IEC 62321-6:2015, IEC 62321-8:2017, EN ISO 12100:2010,
EN IEC 55014-2:2021, EN 62841-1:2015+AC:2015, IEC 62321-4:2013+A1:2017, IEC 62321-12:2023,
IEC 62321-3-1:2013, ISO 17075-1:2017*

The technical documentation required to demonstrate that the product(s) meet(s) the requirement(s) of the aforementioned legislation has been compiled and is available for inspection by the relevant enforcement authorities.

The UKCA mark was first applied in: 2024

Product Description: Chainsaw Sharpener
Model Number(s): ECSS3
Serial/Batch Number: Refer to product/package label
Date of Issue: 25/06/2024

Signed:



J.A Clarke

Director

DECLARATION OF CONFORMITY - CE



Clarke[®]
INTERNATIONAL

Fitzwilliam Hall, Fitzwilliam Place, Dublin 2

DECLARATION OF CONFORMITY

This is an important document and should be retained.

We hereby declare that this product(s) complies with the following legislation:

2014/30/EU	Electromagnetic Compatibility Directive
2006/42/EC	Machinery Directive
2011/65/EU	Restriction of Hazardous Substances (RoHS) Directive

The following standards have been applied to the product(s):

EN 62841-3-10:2015+AC:2016+A11:2017, IEC 62321-1:2013, IEC 62321-2:2021, IEC 62321-5:2013,
EN IEC 61000-3-2:2019+A1:2021, IEC 62321-7-1:2015, IEC 62321-7-2:2017, EN IEC 55014-1:2021,
EN 61000-3-3:2013+A1:2019+A2:2021, IEC 62321-6:2015, IEC 62321-8:2017, EN ISO 12100:2010,
EN IEC 55014-2:2021, EN 62841-1:2015+AC:2015, IEC 62321-4:2013+A1:2017, IEC 62321-12:2023,
IEC 62321-3-1:2013, ISO 17075-1:2017

The technical documentation required to demonstrate that the product(s) meet(s) the requirement(s) of the aforementioned legislation has been compiled and is available for inspection by the relevant enforcement authorities.

The CE mark was first applied in: 2024

Product Description:	Chainsaw Sharpener
Model Number(s):	ECSS3
Serial/Batch Number:	Refer to product/package label
Date of Issue:	25/06/2024

Signed:

J.A Clarke

Director

A SELECTION FROM THE VAST RANGE OF

Clarke®

QUALITY PRODUCTS



AIR COMPRESSORS
From DIY to industrial, Plus air tools, spray guns and accessories.

GENERATORS
Prime duty or emergency standby for business, home and leisure.

POWER WASHERS
Hot and cold, electric and engine driven - we have what you need

WELDERS
Mig, Arc, Tig and Spot. From DIY to auto/industrial.

METALWORKING
Drills, grinders and saws for DIY and professional use.

WOODWORKING
Saws, sanders, lathes, mortisers and dust extraction.

HYDRAULICS
Cranes, body repair kits, transmission jacks for all types of workshop use.

WATER PUMPS
Submersible, electric and engine driven for DIY, agriculture and industry.

POWERTOOLS
Angle grinders, cordless drill sets, saws and sanders.

STARTERS/CHARGERS
All sizes for car and commercial use.



PARTS & SERVICE: 0208 988 7400

Parts Enquiries
Parts@clarkeinternational.com

Servicing & Technical Enquiries
Service@clarkeinternational.com

SALES: UK 01992 565333 or Export 00 44 (0)1992 565335

Clarke® INTERNATIONAL Hemnall Street, Epping, Essex CM16 4LG
www.clarkeinternational.com